



Ceramic Water Dispenser

Model 900114



TO REDUCE THE RISK OF INJURY AND PROPERTY DAMAGE, USER MUST READ THIS MANUAL BEFORE ASSEMBLING, INSTALLING & OPERATING DISPENSER.

SAVE THIS MANUAL FOR FUTURE USE

CLEAN CERAMIC BOWL

Notice: DO NOT use this dispenser without properly cleaning.

Clean inside and outside of Ceramic Bowl using a soft damp cloth with dish washing soap, rinse and dry.

ASSEMBLE STAND

1. Insert Upper Stand (4) over Lower Stand (5).
2. Secure Plate (3) to Stand Assembly using one Large Screw (1) in the center and four Smaller Screws (2).

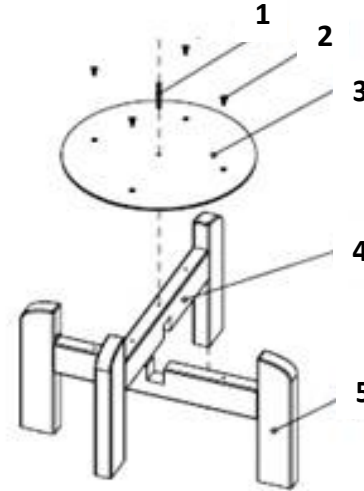

SET UP

1. Place Dispenser on stand.
2. Place protective plastic ring on dispenser.
3. Remove cap from 3 or 5 gallon water bottle. Quickly turn water bottle onto dispenser. Water will automatically flow from bottle into dispenser.
4. Place cup, glass or pitcher under spout.
5. Open nozzle to make water flow.

CLEANING AND CARE

1. For best taste, clean inside of Dispenser at least twice a year to remove mineral scaling.
2. To prevent accidentally tipping unit over, clean Dispenser and surrounding area after removing water bottle.
3. Clean inside and outside of Dispenser using a soft damp cloth with dish washing soap, rinse and dry.

LIMITED WARRANTY

Primo Water Corporation, ("Vendor") warrants to the original purchaser of this dispenser, and to no other person, that if this dispenser is assembled and operated in accordance with the printed instructions accompanying it, then for a period of one (1) year from the date of purchase, all parts in such dispenser shall be free from defects in material and workmanship. Vendor may require reasonable proof of your date of purchase from an authorized retailer or distributor. Therefore, you should retain your sales slip or invoice. The Limited Warranty shall be limited to repair or replacement of parts, which prove defective under normal use and service and which Vendor shall determine in its reasonable discretion upon examination to be defective. Before returning any parts, you should contact Vendor's Customer Service Department using the contact information listed below. If Vendor confirms, after examination, a defect covered by this Limited Warranty in any returned part, and if Vendor approves claim, Vendor will replace such defective part without charge. If you return defective parts, transportation charges must be prepaid by you. Vendor will return replacement parts to original purchaser, freight or postage prepaid.

The Limited Warranty does not cover any failures or operating difficulties due to accident, abuse, misuse, alteration, misapplication, improper installation or improper maintenance or service by you or any third party, or failure to perform normal and routine maintenance on the dispenser, as set out in the User's Manual. In addition, the Limited Warranty does not cover damages to the finish, such as scratches, dents, discoloration or rust after purchase.

The Limited Warranty is in lieu of all other express warranties. Vendor disclaims all warranties for products that are purchased from seller other than authorized retailers or distributors. AFTER THE PERIOD OF THE ONE (1) YEAR EXPRESS WARRANTY, VENDOR DISCLAIMS ANY AND ALL IMPLIED WARRANTIES, INCLUDING WITHOUT LIMITATION THE IMPLIED WARRANTIES OF MERCHANTABILITY AND FITNESS FOR A PARTICULAR PURPOSE. FURTHER, VENDOR SHALL HAVE NO LIABILITY WHATSOEVER TO PURCHASER OR ANY THIRD PARTY FOR ANY SPECIAL, INDIRECT, PUNITIVE, INCIDENTAL, OR CONSEQUENTIAL DAMAGES. Vendor assumes no responsibility for any defects caused by third parties. This Limited Warranty gives the purchaser specific legal rights; a purchaser may have other rights depending upon where he or she lives. Some jurisdictions do not allow exclusion or limitation of special, incidental or consequential damages, or limitations on how long a warranty lasts, so the above exclusion and limitations may not apply to you.

Primo Water Corporation
101 N. Cherry St. Suite 501, Winston-Salem, NC 27101
1-866-429-7566
www.PrimoWater.com

PN O-063 © 2016